

PN SERIES: PN80 CEILING / RAIL MOUNTED

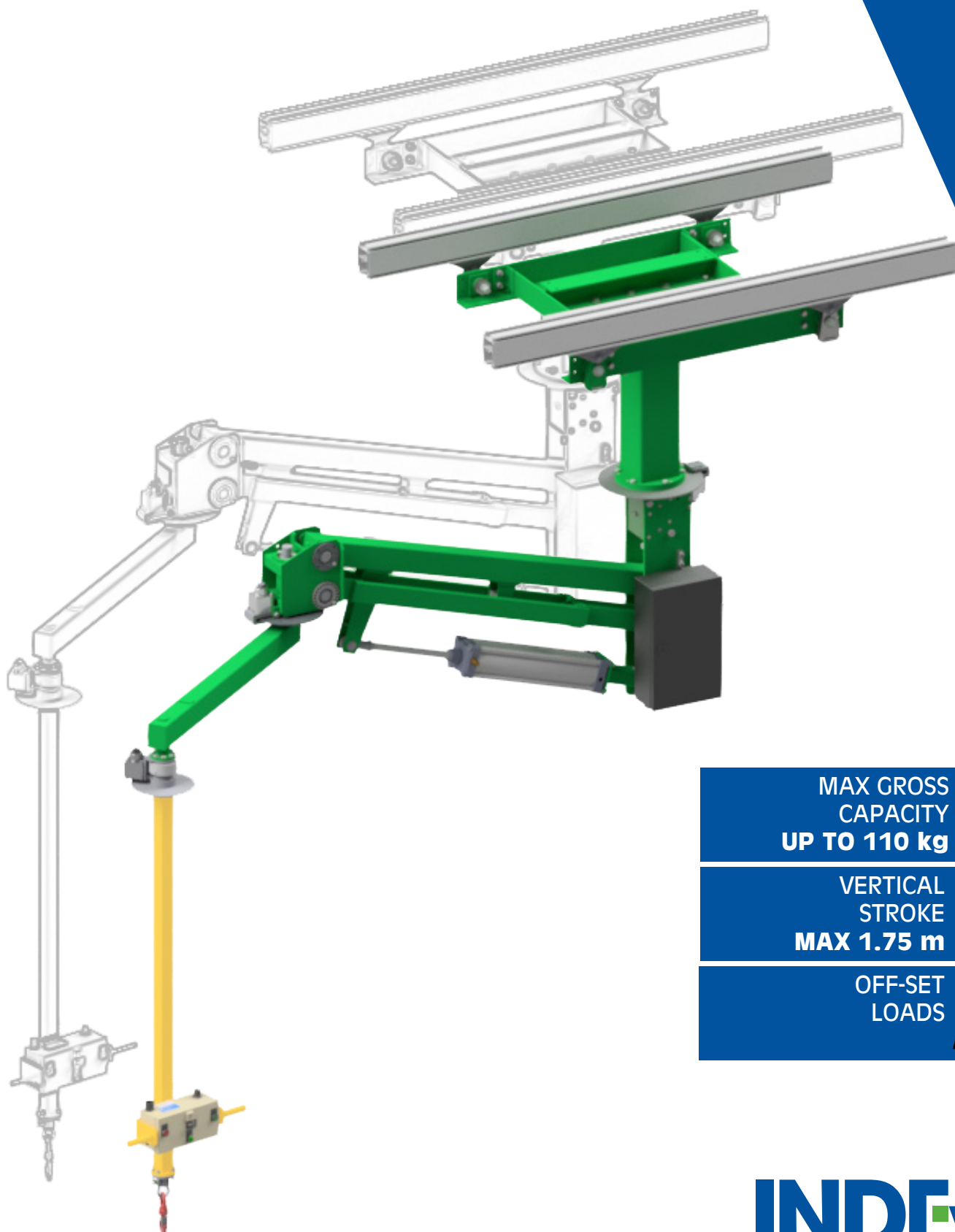

MAX GROSS
CAPACITY
UP TO 110 kg



VERTICAL
STROKE
MAX 1.75 m



OFF-SET
LOADS

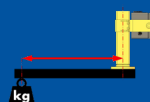

PN SERIES: PN80 CEILING / RAIL MOUNTED

Model		PN 80	PN 80 + ⁽⁴⁾
SQ⁽¹⁾ (Max Load capacity)	kg	80	110
Min Load capacity	kg	10	10
L1	mm	1620	1620
L2	mm	1080	1080
R1*	mm	2700	2700
R2	mm	907	907
RH	mm	-	715
A⁽²⁾	mm	4293	4293
B⁽²⁾	mm	1602	1602
C⁽²⁾	mm	690	690
D Vertical stroke	mm	1751	1751
E⁽²⁾	mm	2010	2010
Weight (with column and load)	kg	336	477
Fv max⁽³⁾	daN	382	542
Mges max⁽³⁾	daNm	520	520

(1) Nominal load capacity SQ is determined with a compressed air supply of minimum 0,65 MPa (6,5 bar) and standard off-set load.

(2) Within certain limits, these values can be modified to suit specific requirements.

(3) Values including the relevant safety factor, according to UNI EN 13001.

(4) With counterweights.

* Most common configurations. Other arm lengths available, all values change accordingly.

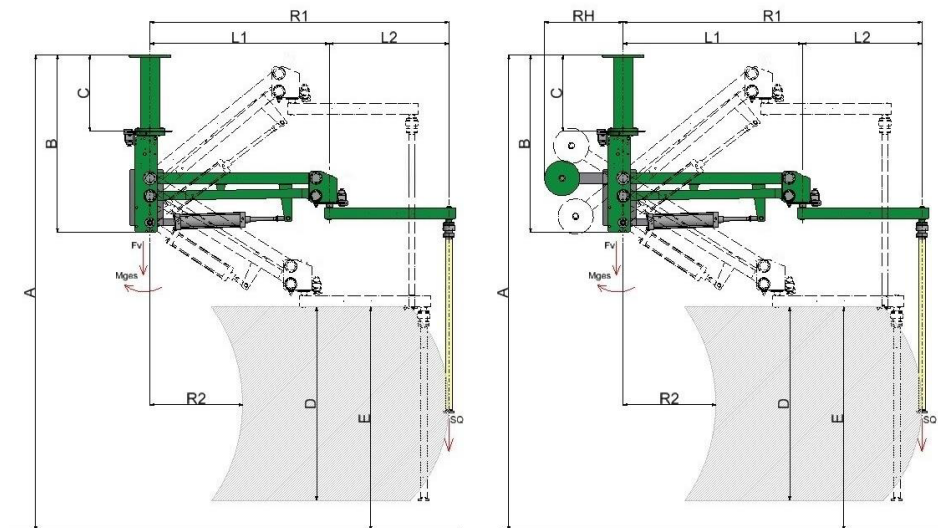

GENERAL TECHNICAL SPECIFICATIONS

Standard features:

- Air pressure 0,65 MPa (6,5 bar)
- Noise level < 70 dB (A)
- Lift speed from 15 to 30 m/min
- Main column axis brake
- Intermediate joint axis brake
- Continuous column rotation (not available with motorized sliding trolley)
- Slow descent in case of pressure failure
- Load balancing: standard, 1 load preset

Available options:

- Continuous swivel joint on the tool axis
- Lifting capacity limiter
- Brake for up/down movement
- Special painting
- Sliding trolley
- Limit switch for the main and intermediate joint axis
- Load balancing: adjustment system for different load weights

Due to continuous product improvement, these specifications may change without notice.

This document is property of INDEVA S.p.A.; any partial or full reproduction without written authorization by the owner is prohibited.

WORKING ENVIRONMENT REQUIREMENTS

- Relative humidity rate: 30% to 90%
- Working temperature 5 to 50 °C

CONFIGURATION CHART

