

Liftronic Air column mounted

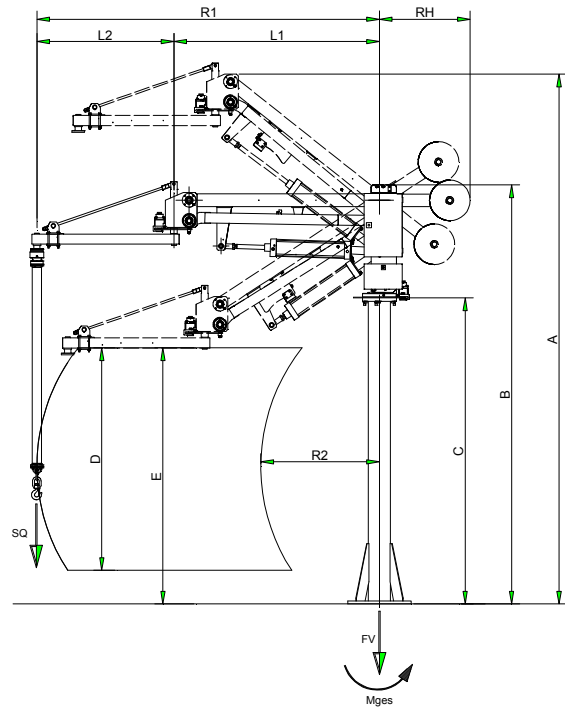

Model	Technical Specifications - Column mounted						
		LA080		LA160		LA250	
SQ * (Max Load capacity)	Kg	80	110****	160	210****	250	310****
Max protrusion from tool axis	mm	300	-	300	-	500	-
Min. Load Capacity	kg	10	10	12	12	15	15
L1	mm	1620	1620	1635	1635	1565	1565
L2	mm	1080	1080	1065	1065	1040	1040
R1	mm	2700	2700	2700	2700	2605	2605
R2	mm	907	907	935	935	900	900
RH	mm	--	715	--	910	--	960
A **	mm	4293	4293	4388	4388	4172	4172
B **	mm	3300.5	3300.5	3444	3444	3346.5	3346.5
C **	mm	2410	2410	2470	2470	2300	2300
D vertical stroke	mm	1752	1752	1716	1716	1451	1451
E **	mm	2007	2007	2012	2012	2002	2002
Weight	Kg	290	408	465	620	548	713
Fv max ***	daN	466	663	780	1050	1010	1300
Mges max ***	daNM	520	450	957	990	1410	1360

- \* Nominal load capacity SQ is determined with a compressed air supply of minimum 6.5 bars .
- \*\* Within certain limits, these values can be modified for special client requirements.
- \*\*\* Values including the relevant safety factor, as per CNR 10021/85 (Steel structures for lifting equipment)
- \*\*\*\*With counterweights and reinforcement for arm. The load capacity increase over the nominal load capacity can be used only to counterbalance the weight of the tooling

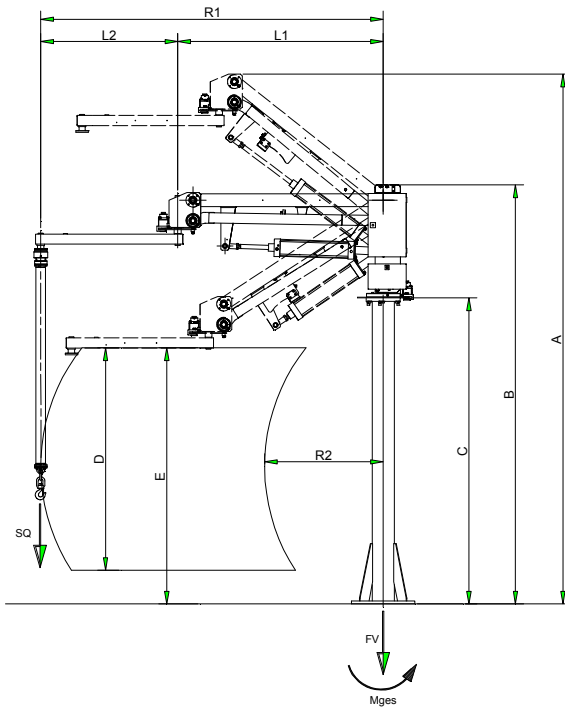

SCAGLIA INDEVA S.p.A. italy  
info@it.indevagroup.com  
[www.indevagroup.com](http://www.indevagroup.com)

## Liftronic Air Series Balancer Technical Specifications GENERAL

File created on  
15/12/2008

Update 07/06/2011

### General Technical Specifications

- Air pressure 6.5 bars
- Power supply 115/230V A/C 50/60Hz
- Power consumption 100VA
- Enclosure protection IP54
- Max working temperature 0 to 40 °C
- Noise level < 70 dB(A)
- Lift speed from 15 to 30 m/min
- Main column axis brake
- Intermediate joint axis brake
- Column rotation 360°
- Tool axis rotation 550° (optional continuous)
- Slow descent in case of pressure failure

### Available options (see specific technical sheets )

- Rotating joint on the articulate axis
- System lock for the lift capacity
- Brake for up/down movement
- Special painting
- Steel platform
- Limit switch for the main and intermediate joint axis

### General information:

- Balancing type:** self balancing
- Min. lighting conditions within the working area:** 300 - 600 lux
- Relative humidity rate:** 30% to 90% +/- 5%
- Applicable standards:**

#### European safety standards 2006/42/CE (Machinery Directive)

Safety requirement in directive 2006/95/CE (Low voltage)

Safety requirement in directive 2004/108/CE (Electro-magnetic compatibility)

**Design standards: CNR 10021/85 (Steel structures for lifting equipment), CNR 10011/86 (Steel products), CNR 10028/85 (Aluminium alloy structures for lifting equipment), CNR 10029/87 (High-resistance steel products) UNI 7670, UNI 7278, DIN 4114, ISO 4304, DIN 1054, FEM/ I-12-1970**

### Safeties (when assembled with tooling):

The system stops automatically when a communication error is detected (fault inside the cables, fault inside an electronic board,...);

The system stops automatically when electric power supply switches off;

The system controls the balancer's pressures (at different levels) and verify the congruencies between them:

The system stops automatically when a fault inside the proportional electrovalve is detected;

The system stops automatically when a fault inside the proportional pneumatical valve is detected;

The system stops automatically when the cilinder pressure isn't congruent with required pressure;

The system stops automatically when the load is losen/fault avoiding the "traditional" raising quick movement;

The system stops automatically when an eccessive acceleration is measured (due to faults);

The system stops automatically when the STOP button is pressed (without the intervention of programmable electronic boards - only electromechanical elements).

The system also generates warning (without stopping the balancer) in order to shown "out of range" working situations.

Maximum load limitation by electronic limit (sealed for the maximum load at factory)